

Energy efficient, eco-friendly hydrocarbon refrigerant with low charge, spark-free components, providing the greatest reliability. Designed with detailed quality to meet all food safety requirements of the foodservice industry



KEY FEATURES



Electronic Temperature Control

Ensures optimal equipment performance by maintaining products at the ideal temperature for consumption.



Eco Friendly Refrigerant

Environmentally friendly hydrocarbon refrigerant has low Global Warming Potential (GWP). Meets all USA refrigerant and energy standards



Electronic Fan Motors

These motors provide improved performance by using only a fraction of the energy required by shaded pole motors.

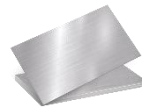

Stainless Steel Material

High quality material for food preservation, complying with safety and hygiene standards.

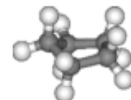

Cyclopentane Insulation Foam

It is ecofriendly as it does not contain CFC (Chlorofluorocarbons) or HFC (hydrochlorofluorocarbons) and is a highly efficient insulator.

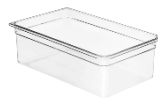

Pans

Includes twelve (8) 1/6" size pans (4" deep)

TECHNICAL SPECIFICATIONS

Exterior Dimensions		Interior Dimensions	
H: 41 3/4"	106 cm	H: 25 7/8"	66 cm
W: 28 7/8"	73.5 cm	W: 24 3/8"	62 cm
D: 30 7/8"	78 cm	D: 25 5/8"	65 cm

Doors	1
Door construction	Solid stainless
Shelves	1
Shelves Size	10 1/8" 25.5 cm 22 7/8" 58 cm
External Material	Stainless Steel
Internal Material	Stainless Steel

REFRIGERATION PERFORMANCE DATA

Refrigerant	R290 3.4 Oz (0.050 kg)	
Energy Consumption	2.355 kW/24h	
Compressor Power	1/5" HP	
Condenser	Dynamic	
Thermostat setting default	32.9°F (0.5°C)	41°F (5°C)

ELECTRICAL DATA

Power supply	115V / 60 Hz	
AMPS	2 A	
Cord length	118.11" 300 cm)	
Lighting	NA	
Plug type	NEMA 5-15P	
Controller	CIR EVO 2V0	

LOGISTIC DATA

Trailer Loads	53": 72		
Unit weight	Gross		Net
	104.75 kg	231 lb	89 kg 192.21 lb
Dimensions w/packaging	H: 46" 3/4		118.9 cm
	W: 34 1/8"		86.5 cm
	D: 33 7/8"		86.2 cm

PRODUCT VIEWS

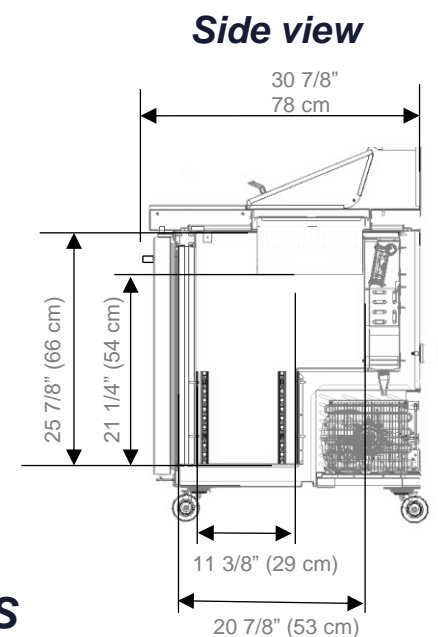
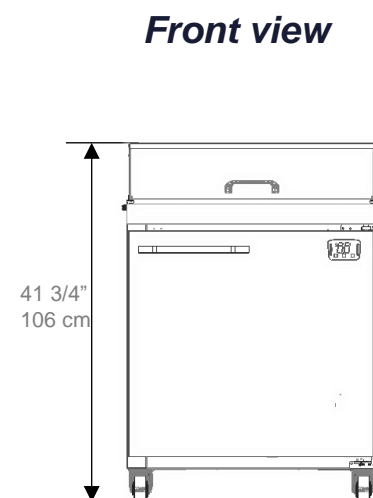
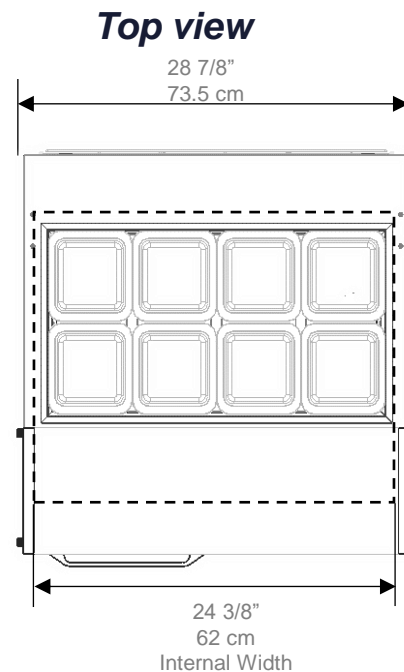

ADDITIONAL FEATURES



**1/6" size pans (6" deep)
(Optional)**

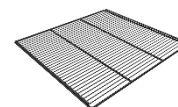

Black Shelves



Pre - installed Casters

*Energy consumption based on ANSI/ASHRARE Standard 72-2005

*BMAD System (Low maintenance high performance)

*Dimensions rounded up to the nearest inch or centimeter

*Specifications subject to change without notice

*H:Height, W:Width, D:Depth

Customer Service and warranty

Five years limited warranty, includes parts and labor.

An additional two warranty is issued on the compressor (USA & Canada only).

Operators must follow installation and operational guidelines per Imbera Users Manual.

Each cooler must be connected directly to a single power supply, otherwise warranty will be voided.

Customer service: 866.548.5770